

SPECIFICATION FOR APPROVAL

1/2W, 1206, Low Resistance Chip Resistor (Lead free / Halogen Free)

1. Scope

This specification applies to 1.6mm x 3.2mm size 1/2W, fixed metal film chip resistors rectangular type for use in electronic equipment.

2. Type Designation

RL1632 H - □□□□ □
 (1) (2) (3) (4)

Where

(1) Series No.

(2) H = H Type

(3) Resistance value :

For example - -

Four digits of number

R005 = 5mΩ

R100 = 100mΩ

(4) Resistance tolerance

F = ± 1%

G = ± 2%

J = ± 5%

3. Outline Dimensions and Marking

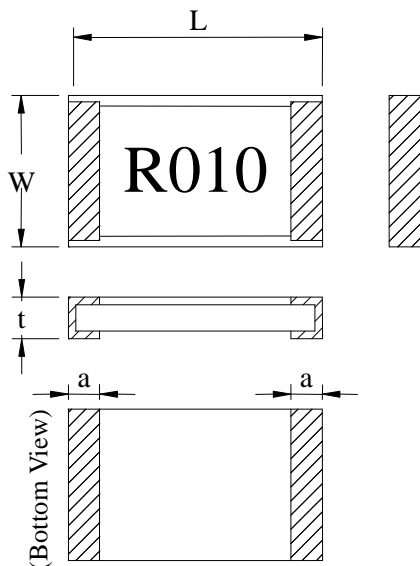

Code Letter	Dimensions (mm)
	1632
L	3.2 ± 0.20
W	1.6 ± 0.20
a	0.50 ± 0.15
t	0.80 ± 0.15

Four digits :

R010 = 10mΩ

R100 = 100mΩ

Figure 1. Construction Dimensions



SPECIFICATION FOR APPROVAL

4. Ratings

Power Ratings*	1/2W
Resistance Value	5~150mΩ
Resistance Tolerance	± 1%(F) , ± 2%(G) , ± 5%(J)
Temperature Coefficient of Resistance	(≤10mΩ) ± 100ppm/°C (>10mΩ) ± 50ppm/°C
Operation Temperature Range	-55°C ~ +170°C
Insulation Resistance	Over 100MΩ
Maximum Working Voltage (V)	(P*R) ^{1/2}

Note * :

Power ratings is based on continuous full load operation at rated ambient temperature of 70°C. For resistors operated at ambient temperature in excess of 70°C, the maximum load shall be derated in accordance with the following curve.

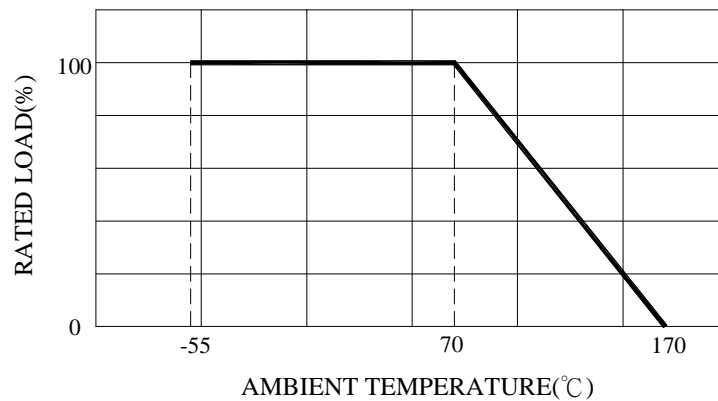

Figure 2. : Power Temperature Derating Curve



SPECIFICATION FOR APPROVAL

5. Characteristics

Test Item	Condition of Test	Requirements
Short Time Overload	2.5 * rated voltage for 5 seconds Refer to JIS C 5201-1 4.13	$\Delta R : \pm (0.5\% + 0.0005\Omega)$ Without significant damage by flashover (spark, arching), burning or breakdown etc.
Insulation Resistance	The resistor shall be cramped in the metal block and tested , as shown below. Test voltage : $100 \pm 15V_{DC}$ for 1 minute Refer to JIS C 5201-1 4.6 Mounting condition G.	Between Electrode and Protection Film $100M\Omega$ or over Between Electrode and Substrate $1,000M\Omega$ or over
Voltage Proof	The voltage : $100V_{AC}$ (rms.) for 1 minute Refer to JIS C 5201-1 4.7	$\Delta R : \pm (0.5\% + 0.0005\Omega)$ Without damage by flashover, fire or breakdown, as shown below.
Thermal Shock	$-55 \sim 125^{\circ}C$ 5 cycles, 15 min at each extreme condition Refer to JIS C 5201-1 4.19	$\Delta R : \pm (0.5\% + 0.0005\Omega)$ Without distinct damage in appearance
Low Temperature Storage	Kept at $-55^{\circ}C$, 1,000 hours Refer to JIS C 5201-1 4.23.4	$\Delta R : \pm (0.5\% + 0.0005\Omega)$ Without distinct damage in appearance
High Temperature Exposure	Kept at $125^{\circ}C$ for 1,000 hours Refer to JIS C 5201-1 4.23.2	$\Delta R : \pm (0.5\% + 0.0005\Omega)$ Without distinct damage in appearance
Solderability	Temperature of Solder : $245 \pm 5^{\circ}C$ Immersion Duration : 3 ± 0.5 second Refer to JIS C 5201-1 4.17	Uniform coating of solder cover minimum of 95% surface being immersed
Resistance to Soldering Heat	Dipped into solder at $270 \pm 5^{\circ}C$ for 10 ± 1 seconds Refer to JIS C 5201-1 4.18	$\Delta R : \pm (0.5\% + 0.0005\Omega)$ Without distinct deformation in appearance

**SPECIFICATION FOR APPROVAL**

Test Item	Condition of Test	Requirements
Load Life	Rated voltage for 1.5 hours followed by a pause 0.5 hour at $70 \pm 2^\circ\text{C}$. Cycle repeated 1000 hours Refer to JIS C 5201-1 4.25	$\Delta R : \pm (0.5\% + 0.0005\Omega)$ Without distinct damage in appearance
Damp Heat with Load	$40 \pm 2^\circ\text{C}$ with relative humidity 90% to 95%. D.C. rated voltage for 1.5 hours ON and 30 minutes OFF. Cycle repeated 1,000 hours Refer to JIS C 5201-1 4.24	$\Delta R : \pm (0.5\% + 0.0005\Omega)$ Without distinct damage in appearance
Mechanical Shock	100 G's for 6 milliseconds. 5 pulses Refer to JIS C 5201-1 4.21	$\Delta R : \pm (0.5\% + 0.0005\Omega)$ Without mechanical damage such as break
Bending Test	Glass-Epoxy board thickness : 1.6mm Bending width : 2mm Between the fulcrums : 90mm Refer to JIS C 5201-1 4.33	$\Delta R : \pm (0.5\% + 0.0005\Omega)$ Without mechanical damage such as break

SPECIFICATION FOR APPROVAL

6. Recommend Land Pattern

	W	L	D
1632	1.78	4.14	1.37

Unit : mm

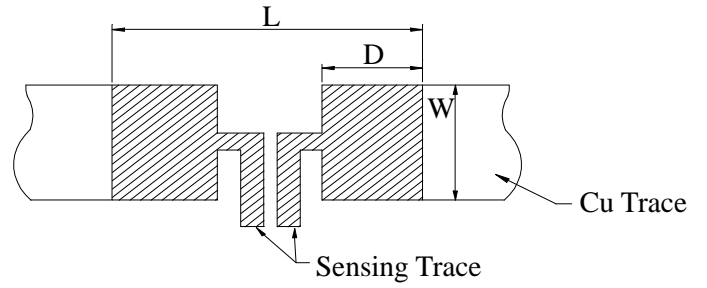

Note : We recommend there is no circuit design between pads to avoid circuit short.



SPECIFICATION FOR APPROVAL

7. Packaging

7-1 Dimensions

7-1-1 Tape packaging dimensions

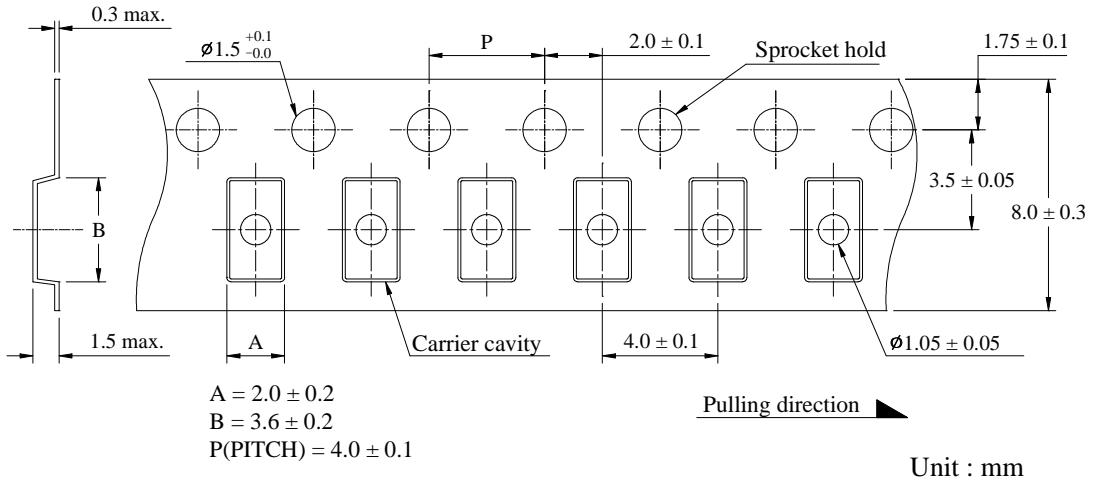

7-1-2 Reel dimensions

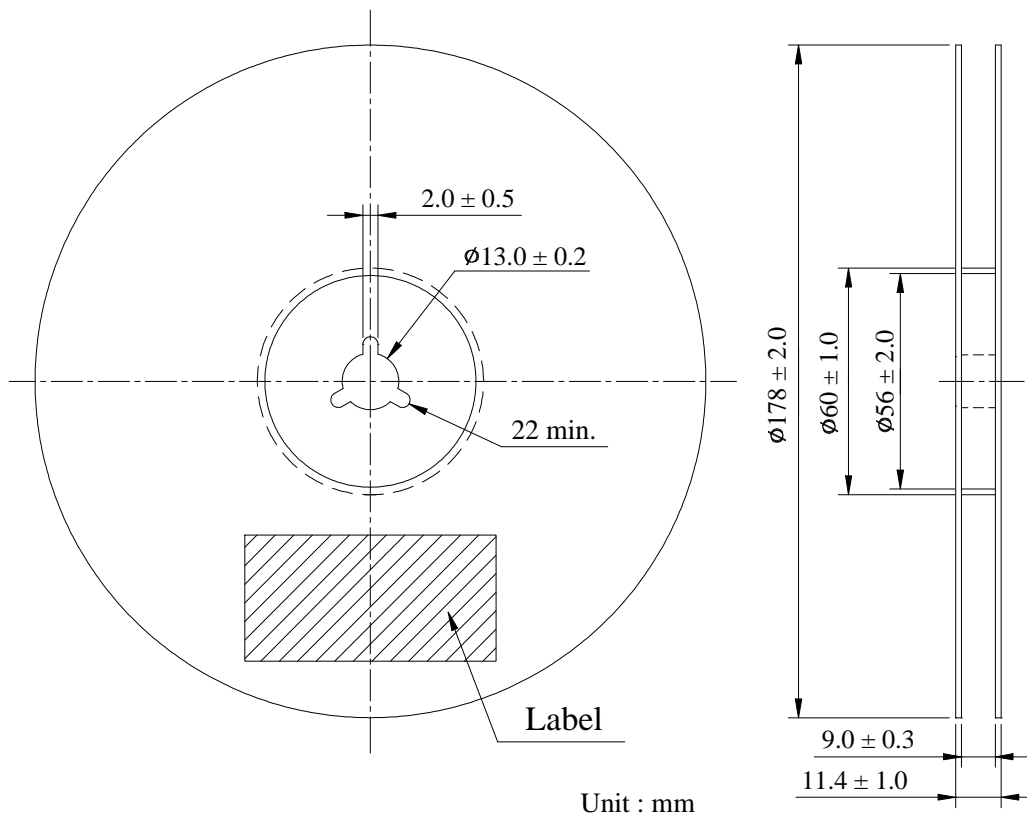

SPECIFICATION FOR APPROVAL

7-2 Peel Strength of Top Cover Tape

The peel speed shall be about 300mm/minute

The peel force of top cover tape shall be between 0.1 to 0.7N

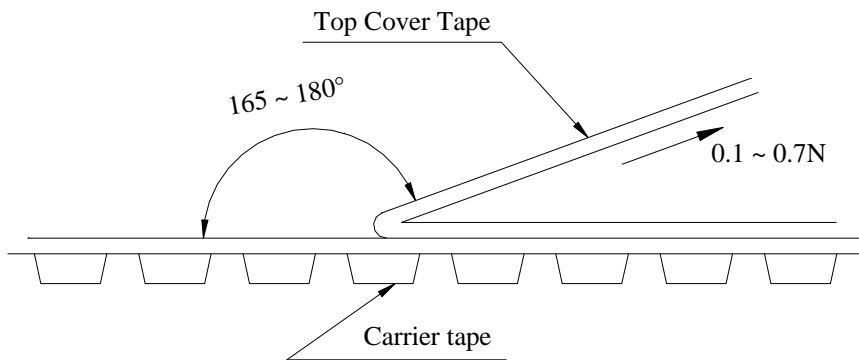

7-3 Number of Taping

2,000 pieces / reel

7-4 Label marking

The following items shall be marked on the reel.

- (1) Type designation
- (2) Quantity
- (3) Manufacturing date code
- (4) Manufacturer's name
- (5) The country of origin