



Digitized Automation for a Changing World

Delta PC-Based Motion Controller AX-8 series



www.deltaww.com





PC-Based Motion Control Solution

Reliable, Flexible, and Highly Integrated

Automation and digitalization play important roles in smart manufacturing. To fulfill this market trend, Delta's PAC platform provides a solution with a high reliability PC-based Motion Controller. Delta is cooperating with the CODESYS® group to utilize its motion control development system and offer a brand new motion control solution based on CODESYS.

Delta's PAC supports EtherCAT communication to simultaneously control field devices, such as the Delta AC Servo Drive ASDA-A2-E, ASDA-A3-E, ASDA-B3-E Series, High Performance Compact Drive MH300 Series, Compact Drive MS300 Series, General Vector Control Drive C2000 Plus Series, and Remote Module R1-EC Series. Delta's motion control solution based on CODESYS fulfills various application demands with its complete and integrated offerings.

Delta's motion control solution is based on CODESYS to integrate the control functions of PLCs, HMIs, and motion controllers into one platform. The platform integrates IEC-61131-3 programming languages and high performance motion control for a wide range of applications and industries.

Delta's PAC platform offers a comprehensive, highly integrated, and flexible industrial PC-based motion control solution to help optimize customers' competitiveness with capabilities for getting ahead of the game.



- Intel x86 CPU with a fan-less and compact design
- Supports EtherCAT, EtherNet/IP, Modbus, and OPC UA protocols
- Provides low-voltage detection and data duplication functions for PACs
- Supports 8 high-speed digital local inputs / outputs, and 1 SSI encoder input
- IEC 61131-3 compliant CODESYS software provides a standardized programming and controller development platform
- Applications : Industrial Robots, Woodworking Machines, Printing Machines, Packaging Machines

Contents

PC-Based Motion Control Solution	1
Product Introduction	3
Product Features	3
Hardware	4
Communication Structure	5
Software Environment	6
Product Information	10
Model Explanation	10
Dimensions	11
Product Specifications	12
EtherCAT Remote Modules	13
Ordering Information	20

Product Features

Compact and Reliable Design

The AX-8 Series adopts a cable-less, fan-less and low power consumption compact design, increasing reliability and saving installation space.

Multiple Peripheral Interfaces for Communication

Equipped with USB ports, serial COM ports, Gbps Ethernet ports and SSD storage for flexible usage

EtherCAT Fieldbus Support

Equipped with built-in EtherCAT fieldbus and supports 64 axes/32 stations with 1ms synchronous servo control

CODESYS-enabled

IEC 61131-3 compliant CODESYS software provides SoftPLC functions, including Function Chart Programming (FBD), advanced Structured Text (ST) for easy programming, and standard Sequential Function Chart (SFC) and Ladder Programming (LD)

High Security

Built-in security IC system for enhanced software and hardware security



Hardware

Hardware Interface

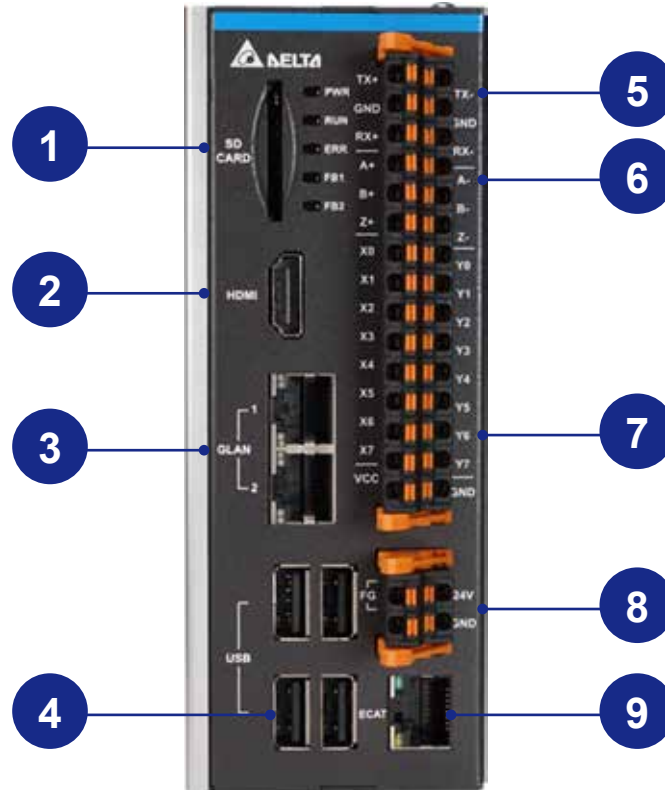

1 Supports SD card extension

- SD Card 3.0 interface
- SD 3.0: Secure Digital eXtended Capacity (SDXC) 32GB~2TB
- SD 2.0: Secure Digital High Capacity (SDHC) 2GB~32GB

2 HDMI output for HDMI LCD monitor

3 Gigabit LAN

- Modbus TCP/IP
- OPC UA Server

4 USB 2.0

5 RS-485/RS-422 COM port or ABS Encoder input

- Supports SSI Encoder

6 INC Encoder input

- OA OB OZ

7 High-speed 8DI/8DO

- DI: NPN or PNP | Max. 5mA/CH
- DO: NPN | Max. 200mA/CH

8 Power input

9 EtherCAT Master port

Communication Structure

Standard EtherCAT Motion Control Fieldbus

Supports EtherCAT communication to simultaneously control field devices, such as the Delta AC Servo Drive ASDA-A2-E, ASDA-A3-E, and ASDA-B3-E Series, High Performance Compact Drive MH300 Series, Compact Drive MS300 Series, General Vector Control Drive C2000 Plus Series, and Remote Module R1-EC Series

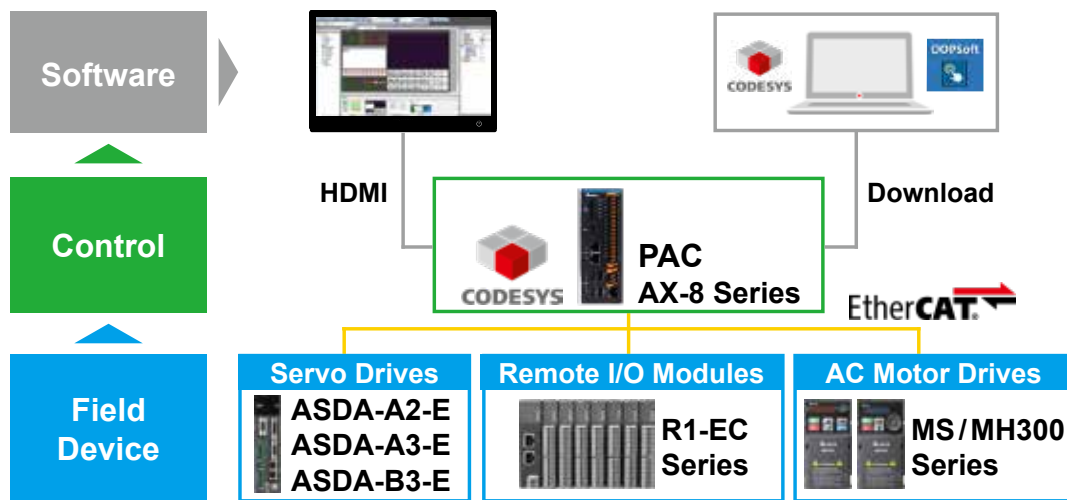

The EtherCAT high-speed motion control system achieves rapid and real-time motion control of multiple axes, and syncs 64-axis motion control within 1ms cycle time. It also uses the XML device description to identify 3rd-party EtherCAT devices.

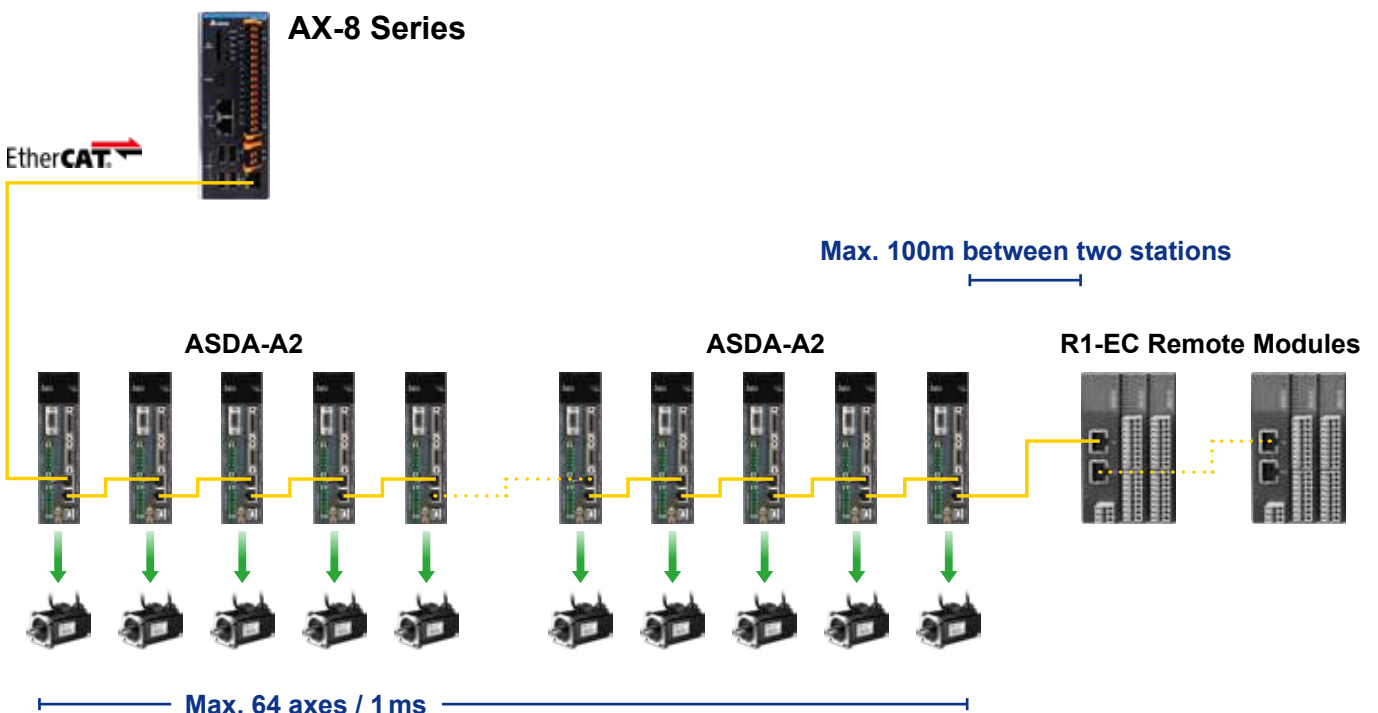

High-performance PC-based Controller Structure

EtherCAT motion controller, servo drives and remote I/O modules

Motion Controller

PC-Based Motion Controller



AX-8 Series

Servo Drives (Note: Please refer to the catalogues of Delta's servo drives and motors ASDA Series for detailed specifications)

AC Servo Drives



ASDA-A2-E



ASDA-A3-E



ASDA-B3-E

Gateway Type Remote Module

Gateway Type E-Bus Remote Power Coupler



R1-EC5500D0

Pulse Remote Module

1-Channel Pulse Remote Module



R1-EC5621D0

Digital Remote Modules

16 Digital Input Remote Module
R1-EC6002D0
R1-EC6022D0



16 Digital Output Remote Module
R1-EC7062D0
R1-EC70A2D0
R1-EC70E2D0
R1-EC70F2D0

Analog Remote Modules

4-Channel Analog Input Remote Module
R1-EC8124D0



4-Channel Analog Output Remote Module
R1-EC9144D0

Communication Structure

Standard OPC UA Server

Built-in OPC UA Server connects with different systems, such as MES, EPR, or PLC systems via Gigabit LAN to integrate with the whole factory system efficiently.

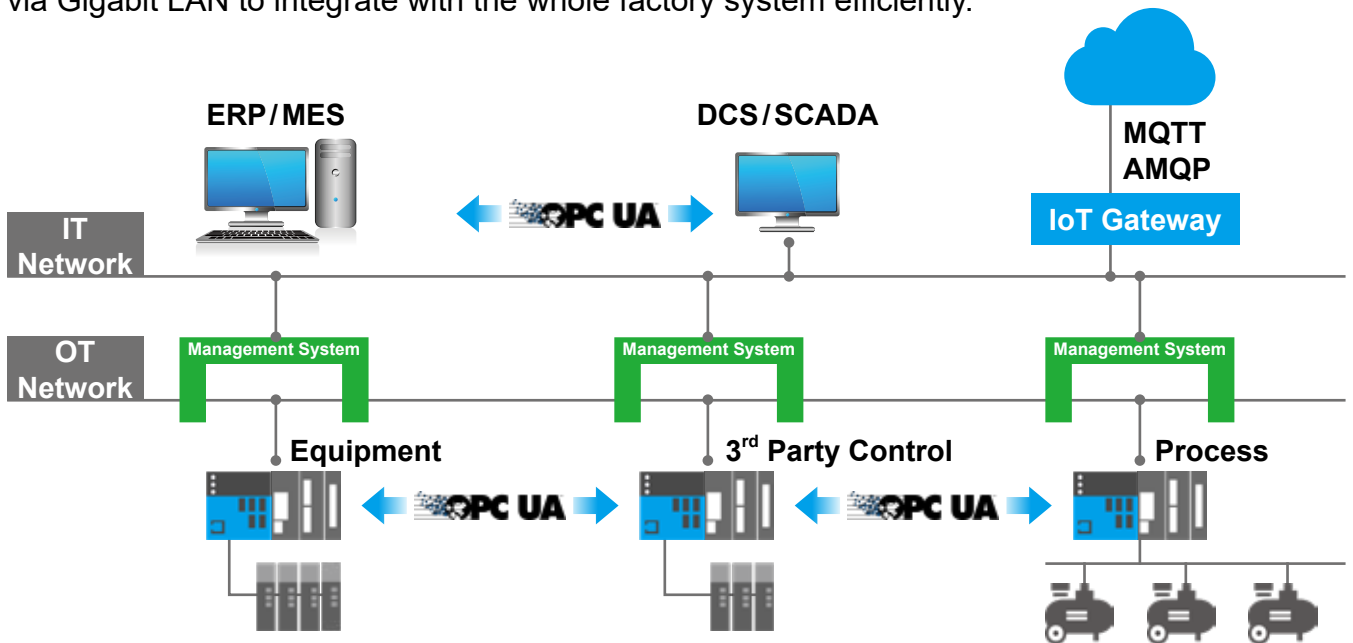

Flexible Network System

- Built-in EtherNet/IP to support star and linear network typology for fast expansion and management
- Compatible with IT networks for more automation applications and industrial 4.0 upgrades

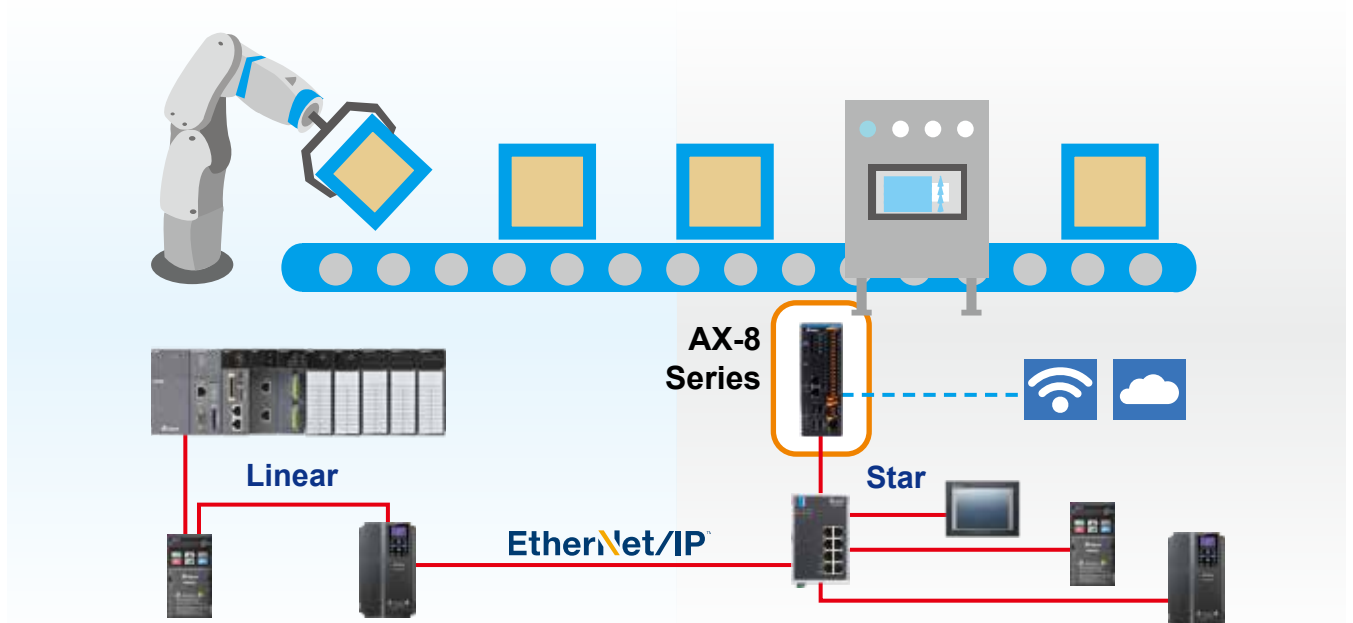

Software Environment

Standard IEC 61131-3 Programming

- Function Chart Programming (FBD)
- Structured Text (ST)
- Sequential Function Chart (SFC)
- Ladder Programming (LD)

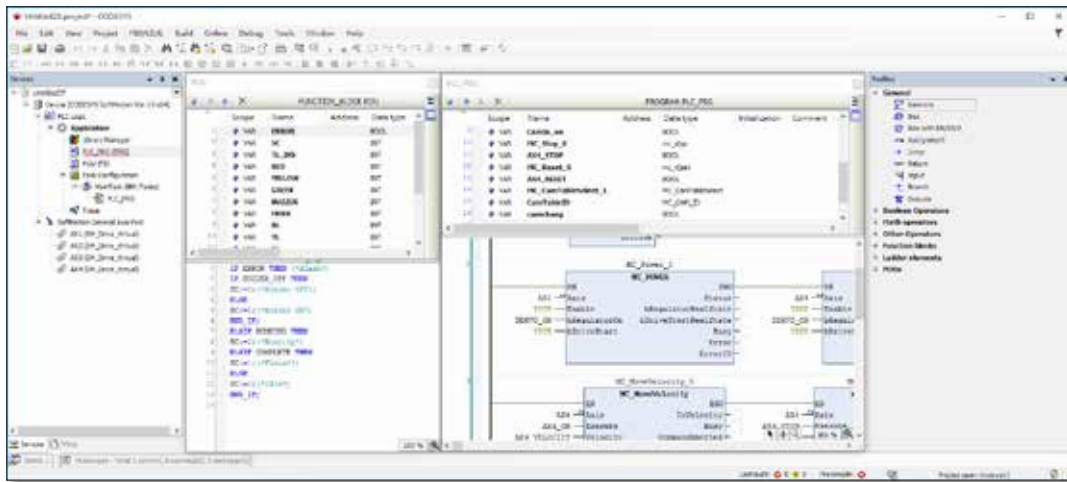

Motion Control Software

Comprehensive functions for configuring, programming, compiling, and debugging; seamlessly integrated for both classic and systematically supported programming

- Supports single or multi-axis movements with PLCopen motion POU's
- Provides E-Cam synchronous control function

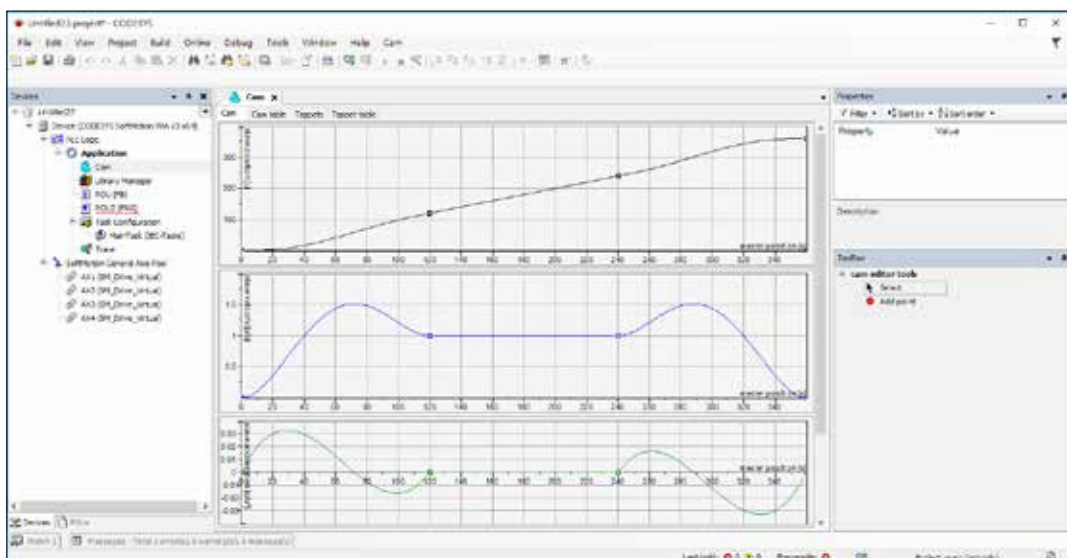

Software Environment

Motion Control Program

- Multi-platform development and application reusability with exchangeable target system descriptions for all CODESYS-compatible devices
- 1ms synchronous cycle to control a total of 64 real and virtual axes
- Motion control using IEC 61131-3 function blocks

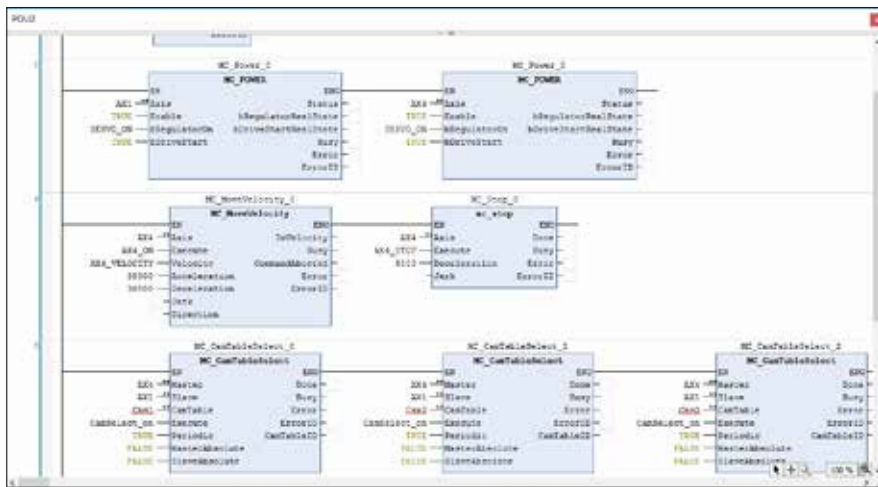

HMI Tag Sharing

With the built-in HMI Software DIAScreen, AX-8 Series also supports variable sharing with HMIs. Supports variable sharing between HMI and AX-8 controller

PC-Based Motion Controller



Product Information

Model Explanation

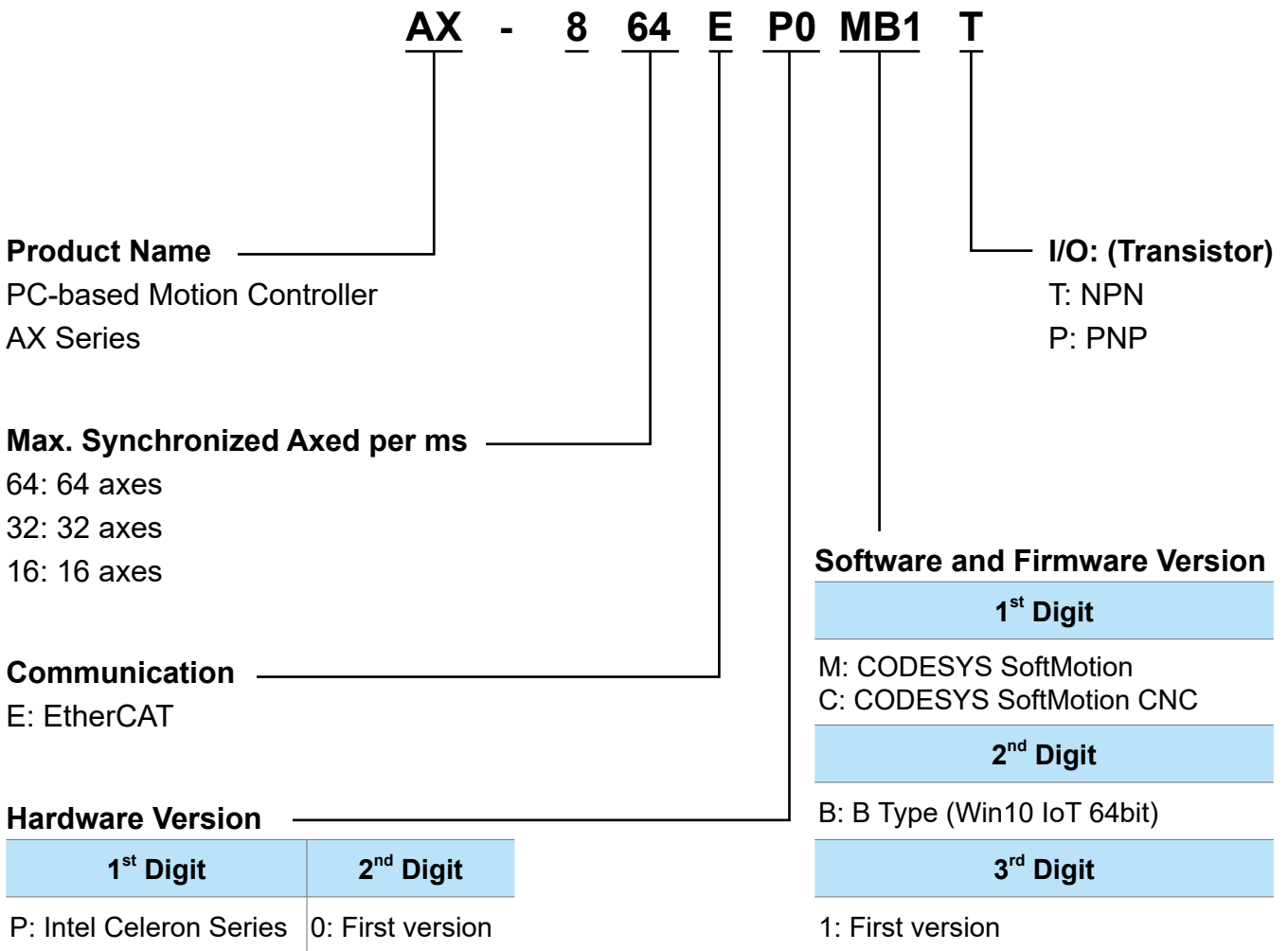

Version Explanation

Software \ Model	SoftMotion AX-8 <input type="checkbox"/> EP0MB1 <input type="checkbox"/>	SoftMotion CNC AX-8 <input type="checkbox"/> EP0CB1 <input type="checkbox"/>
Windows 10 IOT 64bits	<input type="radio"/>	<input type="radio"/>
DIA Screen HMI	<input type="radio"/>	<input type="radio"/>
CODESYS Control RTE SL	<input type="radio"/>	<input type="radio"/>
CODESYS SoftMotion SL	<input type="radio"/>	<input type="radio"/>
CODESYS SoftMotion CNC	<input type="radio"/>	<input type="radio"/>

Note: Only certain CNC and Robot functions are supported. Please contact Delta for available application info before using.

Dimensions (Unit: mm)

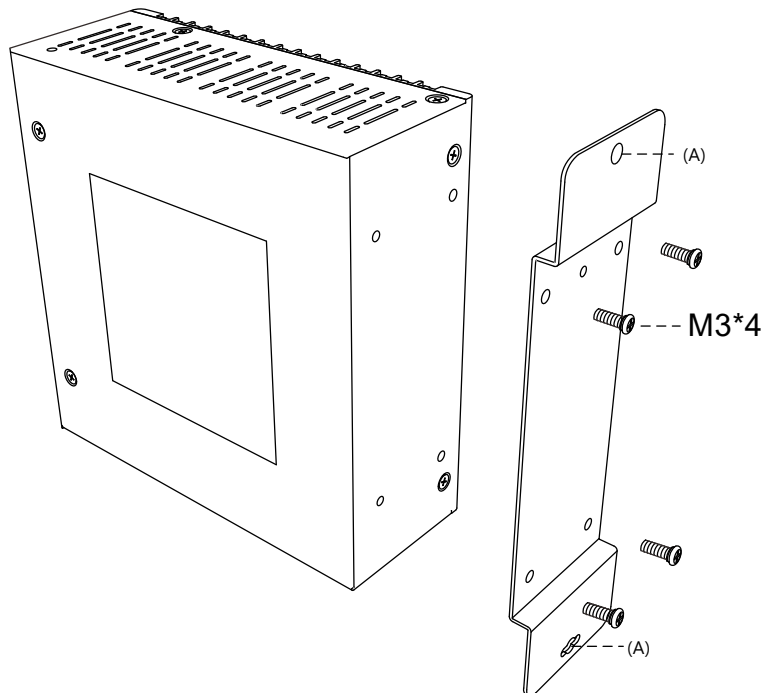
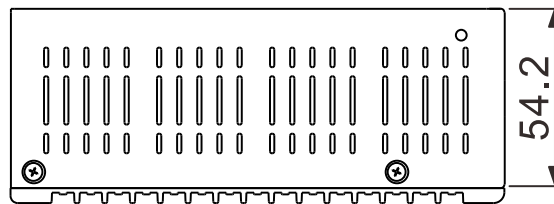
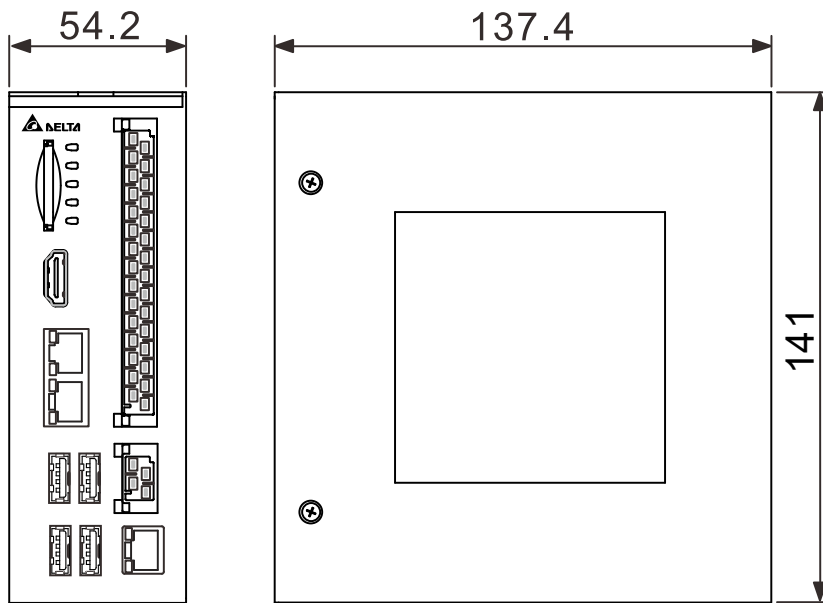

Product Specifications

Model		AX-8 □ EP0MB1 □	AX-8 □ EP0CB1 □
Processor	CPU	Intel® Celeron J1900 2.0 GHz Quad. Core	
	BIOS	AMI BIOS	
	Memory	Built-in DDR3L-1333 4 GB	
	Non-Volatile Memory	96 KB	
Display	Type	HDMI 1.4a × 1	
Input / Output Port	DI / DO	8 DI / 8 DO	
	Transistor	PNP; NPN	
Encoder Input	Input Pulse	A± / B± / Z±	
	Communication Type	SSI × 1	
Execution Cycle	Floating-point Number	30 ns	
Storage	SSD	M.2 module × 1 (Built-in SSD 32G)	
	USB	USB 2.0 × 4	
	SD Card	SD card slot × 1	
	Program Capacity	1 G	
	Temp. Data Storage (I/Q/M)	128KB / 128KB / 5MB	
Power	Input Voltage	24V _{bc} , -15% / +20%	
	Rated Power	48 W	
	Max. curr. consumption	2 A	
RTC Backup Battery		BIOS 3V CR2032 lithium battery × 1	
Dimensions (W) × (H) × (D) mm / Weight		54.2 × 141 × 137.5 / 700g	
Cooling System		Natural	
Axes of Control (1 ms)		64 Axes / 96 Stations	
Communication	Network Port	Ethernet × 2	
	Serial Port	RS-422/485: 115.2 kbps	
Environment	Ambient Temperature	0~50°C	
	Storage Temperature	-30~85°C	
	Humidity	10~90% RH (non-condensing)	
	Vibration Resistance	5~8.3 Hz 3.5 mm, 8.3~150 Hz 1 G, compliant with IEC61131-2	
	Shock Resistance	75G IEC 60068-2-27, half sine, 11 ms duration	
	Protection Rating	IP 20	
	Certifications		
Software	Microsoft Windows	Window 10 IoT	
	Real-time OS	RTE(Based on CODESYS)	
	System Type	Standard Supports SoftMotion PLCopen Part1, 2	Advanced Supports SoftMotion PLCopen Part1, 2, 4

EtherCAT Remote Modules

Gateway Type E-bus Remote Power Coupler

R1-EC5500D0

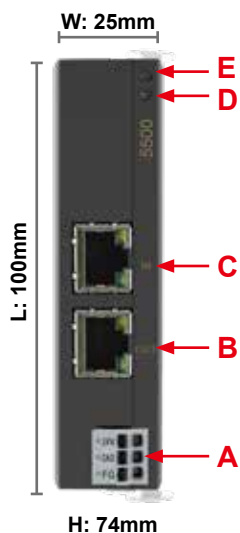

NO.	Description
A	DC Power Input
B	EtherCAT Output
C	EtherCAT Input
D	Status Indicator
B	Power Indicator

Technical Data	R1-EC5500D0
Task Within EtherCAT System	Connect EtherCAT Slave module with 100 baseTX EtherCAT
Data Transfer Medium	Ethernet/EtherCAT cable (min. CAT 5), shielded
Distance Between Stations	100 M (100BASE-TX) between two slaves
Protocol	EtherCAT
Data Transfer Rates	100 Mbaud
Bus Interface	RJ 45x2
Input Voltage	24 V _{DC}
Input Current	50 mA + (E-bus total E-bus current) / 4
Current Supply E-Bus	2A
Electrical Isolation	500 Vrms (Power contact / Supply voltage / Ethernet)
Vibration / Shock Resistance	EN 60068-2-6/EN 60068-2-27/29
EMC Immunity	ESD (IEC 61131-2, IEC 61000-4-2): 8KV Air Discharge EFT (IEC 61131-2, IEC 61000-4-4): Power Line: 2KV Communication I/O: 1KV RS (IEC 61131-2, IEC 61000-4-3): 80 MHz~1 GHz, 10V/m
Operating Environment	Operating temperature: 0°C~50°C; Storage temperature: -20°C~70°C
Weight	55 g (0.12 lb)
Protection Class	IP20
Mounting Type	DIN-rail

1-Channel Pulse Output Remote Module

R1-EC5621D0

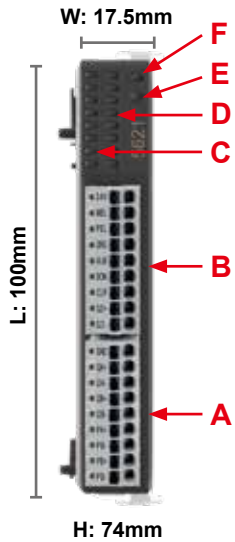

NO.	Description	NO.	Description
A	IO Signal Port	D	IO Signal Indicator
B	IO Signal Port	E	Status Indicator
C	IO Signal Indicator	F	Power Indicator

Input	Description	Input	Description
24V	24V Power	GND	External Ground
MEL	End Limit (-)	QA+	Encoder A Phase (+)
PEL	End Limit (+)	QA-	Encoder A Phase (-)
ORG	Home Signal	QB+	Encoder B Phase (+)
ALM	Servo Alarm	QB-	Encoder B Phase (-)
SON	Servo On	PA+	Pulse Signal (+)
CLR	Reset Servo Alarm	PA-	Pulse Signal (-)
QZ+	Encoder Z Phase (+)	PB+	Dir. Signal (+)
QZ-	Encoder Z Phase (-)	PB-	Dir. Signal (-)

Technical Data	R1-EC5621D0
Number of Outputs	1 channel (PA+, PA-, PB+, PB-)
Number of Inputs	1 channel (QA+, QA-, QB+, QB-, QZ+, QZ-)
Power Supply	Via the E-bus
Signal Voltage	RS422 Level
Max. Output Current	RS422 specification
Base Frequency	1 Hz~4 MHz
Numbers of 24 V Input	4 (MEL, PEL, ORG, ALM)
Numbers of 24 V Output	2 (CLR, SON)
Trigger Voltage (On > Off)	< 8V _{DC}
Trigger Voltage (Off > On)	> 16.5V _{DC}
Max. Current of Each Output Port	30 mA
Current Consumption E-Bus	150 mA
Electrical Isolation	50 Vrms (E-bus / field potential)
Bit Width in the Process Image	32 byte in/out (1 x 16 byte data, 1 x 16 byte control/status)
Vibration / Shock Resistance	EN 60068-2-6/EN 60068-2-27/29
EMC Immunity	ESD (IEC 61131-2, IEC 61000-4-2): 8 KV Air Discharge EFT (IEC 61131-2, IEC 61000-4-4): Power Line: 2 KV Communication I/O: 1KV RS (IEC 61131-2, IEC 61000-4-3): 8 MHz~1 GHz, 10 V/m
Operating Environment	Operating temperature: 0°C~50°C; Storage temperature: -20°C~70°C
Weight	60 g (0.13 lb)
Protection Class	IP20
Mounting Type	DIN-rail

EtherCAT Remote Modules

16-Channel Digital Input Remote Module

R1-EC6002D0/R1-EC6022D0

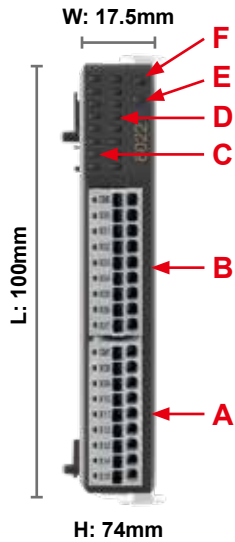

NO.	Description	NO.	Description
A	Port 1 Terminals	D	Port 1 IO Signal X08~X15 (From the top)
B	Port 0 Terminals	E	Status Indicator
C	Port 0 IO Signal X00~X07 (From the top)	F	Power Indicator

Input	Description	Input	Description
CM0	Port 0 COM	CM1	Port 1 COM
X00	Input 0	X08	Input 8
X01	Input 1	X09	Input 9
X02	Input 2	X10	Input 10
X03	Input 3	X11	Input 11
X04	Input 4	X12	Input 12
X05	Input 5	X13	Input 13
X06	Input 6	X14	Input 14
X07	Input 7	X15	Input 15

Technical Data	R1-EC6002D0	R1-EC6022D0
Connection Technology	Single-ended	
Number of Inputs	16	
Nominal Voltage	24 V _{DC} ± 10%	
Signal Type	SINK / SOURCE	
Trigger Voltage (On > Off)	< 8 V _{DC}	
Trigger Voltage (Off > On)	> 16.5 V _{DC}	
Input Filter	100µs	2ms
Input Current	3 mA at each port	
Current Consumption E-Bus	110 mA	
Electrical Isolation	500 V _{rms} (E-bus / field potential)	
Bit Width in the Process Image	16 inputs	
Vibration / Shock Resistance	EN 60068-2-6/EN 60068-2-27/29	
EMC Immunity	ESD (IEC 61131-2, IEC 61000-4-2): 8 KV Air Discharge EFT (IEC 61131-2, IEC 61000-4-4): Power Line: 2KV Communication I/O: 1KV RS (IEC 61131-2, IEC 61000-4-3): 80 MHz~1GHz, 10V/m	
Operating Environment	Operating temperature: 0°C ~ 50°C; Storage temperature: -20°C ~ 70°C	
Weight	55 g (0.12 lb)	
Protection Class	IP20	
Mounting Type	DIN-rail	

16-Channel Digital Output Remote Module

R1-EC7062D0/R1-EC70E2D0/R1-EC70A2D0/R1-EC70F2D0

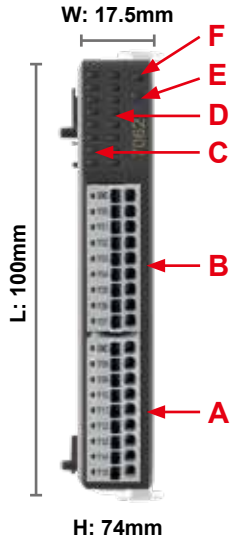

NO.	Description	NO.	Description
A	Port 1 Terminals	D	Port 1 IO Signal Y08~Y15 (From the top)
B	Port 0 Terminals	E	Status Indicator
C	Port 0 IO Signal Y00~Y07 (From the top)	F	Power Indicator

Input	Description	Input	Description
GND *	Port 0 GND	GND	Port 1 GND
24V **	Port 0 24V Input		
Y00	Input 0	Y08	Input 8
Y01	Input 1	Y09	Input 9
Y02	Input 2	Y10	Input 10
Y03	Input 3	Y11	Input 11
Y04	Input 4	Y12	Input 12
Y05	Input 5	Y13	Input 13
Y06	Input 6	Y14	Input 14
Y07	Input 7	Y15	Input 15

* R1-EC7062D0 / R1-EC70E2D0

** R1-EC70A2D0 / R1-EC70F2D0

Technical Data	R1-EC7062D0	R1-EC70E2D0	R1-EC70A2D0	R1-EC70F2D0
Connection Technology	MOSFET			
Signal Type	SINK		SOURCE	
Nominal Voltage	24V _{DC}			
Input Current	0.5 A (Max.)	0.25 A (Max.)		
User-defined Output Disconnection	×	√	×	√
Current Consumption E-bus	120mA	200mA		
Response Time / Frequency	1 KHz			
Trigger Time (OFF > ON)	140 us		160 us	
Trigger Time (ON > OFF)	150 us		110 us	
EMC Immunity	ESD (IEC 61131-2, IEC 61000-4-2): 8 KV Air Discharge EFT (IEC 61131-2, IEC 61000-4-4): Power Line: 2KV Communication I/O: 1 KV RS (IEC 61131-2, IEC 61000-4-3): 80MHz~1 GHz, 10V/m			
Operating Environment	Operating temperature: 0°C~50°C; Storage temperature: -20°C~70°C			
Weight	60 g (0.13 lb)			
Protection Class	IP20			
Mounting Type	DIN-rail			

EtherCAT Remote Modules

4-Channel Analog Input Remote Module

R1-EC8124D0

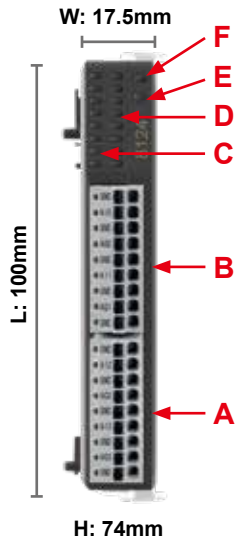

NO.	Description	NO.	Description
A	CH3/CH4 Signal port	D	CH3/CH4 Signal Indicator
B	CH1/CH2 Signal port	E	Status Indicator
C	CH1/CH2 Signal Indicator	F	Power Indicator

Input	Description	Input	Description
GND	Analog Ground	GND	Analog Ground
AI0	CH1 Voltage/Current Input	AI2	CH3 Voltage/Current Input
GND	Analog Ground	GND	Analog Ground
AG0	CH1 Current COM*	AG2	CH3 Current COM*
GND	Analog Ground	GND	Analog Ground
AI1	CH2 Voltage/Current Input	AI3	CH4 Voltage/Current Input
GND	Analog Ground	GND	Analog Ground
AG1	CH2 Current COM*	AG3	CH4 Current COM*
GND	Analog Ground	GND	Analog Ground

* In current mode: please connect current COM to GND; In voltage mode: please disconnect this COM

Technical data	R1-EC8124D0
Number of Inputs	4 (single-ended)
Power Supply	via the E-bus
Signal Voltage	$\pm 10V / \pm 5V$
Internal Resistance	$> 1M\Omega$
Input Filter Limit Frequency	1 KHz ~ 10 KHz
Resolution	16 bit
Over Sampling Rate	0 ~ 64
Conversion Time	2 us ~ 191 us (depends on Over Sampling Rate)
Measuring Error	$< \pm 0.2\%$ (relative to full scale value)
Electrical Isolation	500 Vrms (E-bus/signal voltage)
Current Consumption E-Bus	300 mA
Bit Width in the Process Image	input: 4 x 16 byte data, 4 x 16 byte control/status
Vibration / Shock Resistance	EN 60068-2-6/EN 60068-2-27/29
EMC Immunity	ESD (IEC 61131-2, IEC 61000-4-2): 8 KV Air Discharge EFT (IEC 61131-2, IEC 61000-4-4): Power Line: 2KV Communication I/O: 1KV RS (IEC 61131-2, IEC 61000-4-3): 80MHz ~ 1 GHz, 10V/m
Operating Environment	Operating temperature: 0°C ~ 50°C; Storage temperature: -20°C ~ 70°C
Weight	60 g (0.13 lb)
Protection Class	IP20
Mounting Type	DIN-rail

4-Channel Analog Output Remote Module

R1-EC9144D0

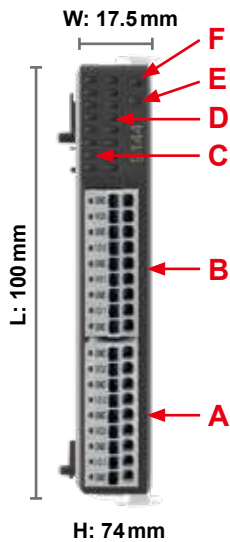

NO.	Description	NO.	Description
A	CH3/CH4 Signal Port	D	CH3/CH4 Signal Indicator
B	CH1/CH2 Signal Port	E	Status Indicator
C	CH1/CH2 Signal Indicator	F	Power Indicator

Input	Description	Input	Description
GND	Analog Ground	GND	Analog Ground
VO0	CH1 Voltage Output	VO2	CH3 Voltage Output
GND	Analog Ground	GND	Analog Ground
IO0	CH1 Voltage Output	IO2	CH3 Voltage Output
GND	Analog Ground	GND	Analog Ground
VO1	CH2 Voltage Output	VO3	CH4 Voltage Output
GND	Analog Ground	GND	Analog Ground
IO1	CH2 Voltage Output	IO3	CH4 Voltage Output
GND	Analog Ground	GND	Analog Ground

Technical Data	R1-EC9144D0
Number of Inputs	4 (single-ended)
Power Supply	via the E-bus
Signal Voltage Output	$\pm 10V / \pm 5V / 0 \sim 5V / 0 \sim 10V$
Current Output	$0 \sim 20\text{mA} / 4 \sim 24\text{mA} / 0 \sim 24\text{mA}$
Load	$> 1\text{K}\Omega$ (short-circuit-proof)
Resolution	16 bit
Conversion Time	80 μs
Measuring Error	$< \pm 0.2\%$ (relative to full scale value) voltage output $< \pm 0.3\%$ (relative to full scale value) current output
Electrical Isolation	1000 Vrms (E-bus/signal voltage)
Current Consumption E-bus	550 mA
Bit Width in the Process Image	Output: 4 x 16 byte, 4 x 16-bit analog output
Vibration / Shock Resistance	EN 60068-2-6/EN 60068-2-27/29
EMC Immunity	ESD (IEC 61131-2, IEC 61000-4-2): 8KV Air Discharge EFT (IEC 61131-2, IEC 61000-4-4): Power Line: 2KV Communication I/O: 1KV RS (IEC 61131-2, EC 61000-4-3): 80MHz~1GHz, 10V/m
Operating Environment	Operating temperature: $0^{\circ}\text{C} \sim 50^{\circ}\text{C}$; Storage temperature: $-20^{\circ}\text{C} \sim 70^{\circ}\text{C}$
Weight	60 g (0.13 lb)
Protection Class	IP20
Mounting Type	DIN-rail

EtherCAT Remote Modules

Manual Pulse Generator (MPG) Module

R1-EC5614D0

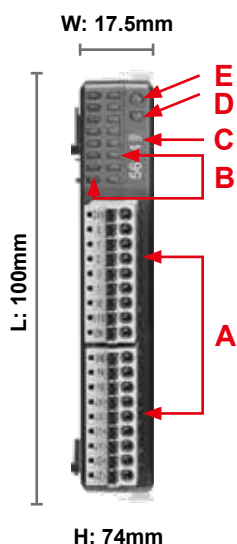

NO.	Description	NO.	Description
A	IO Signal Port	D	Status Indicator
B	IO Signal Indicator	E	Power Indicator
C	Product No.		

Input	Description	Input	Description
GND	External Ground	24V	External Power Input
PA	MPG Pulse Phase A Input	X	X-axis Pulse Chosen Signal
PB	MPG Pulse Phase B Input	Y	Y-axis Pulse Chosen Signal
JX+	JOG X-axis Signal (+)	Z	Z-axis Pulse Chosen Signal
JX-	JOG X-axis Signal (-)	U	U-axis Pulse Chosen Signal
JY+	JOG Y-axis Signal (+)	1	Pulse Magnification (x 1)
JY-	JOG Y-axis Signal (-)	10	Pulse Magnification (x 10)
JZ+	JOG Z-axis Signal (+) / *W-axis	100	Pulse Magnification (x 100)
JZ-	JOG Z-axis Signal (-) / *V-axis	EN	Motion/Setting Execution

*Supports 6-axis MPG via software: JZ+ needs to connect to W-axis signal; JZ- needs to connect to V-axis signal

Technical Data	R1-EC5614
Control Axes	4 / 6 axes
Power Supply	via the E-bus
Pulse Magnification	x1/x10/x100
JOG Input	3 / 2 sets
Sampling Rate	40 KHz
FIFO Length	30 sets
Communication Time	125us - 3276800 us
Trigger Time (ON > OFF)	< 8V _{DC}
Trigger Time (OFF > ON)	> 16.5V _{DC}
Current Consumption E-Bus	180 mA
Electrical Isolation	500Vrms (E-bus/signal power)
Vibration / Shock Resistance	EN 60068-2-6 / EN 60068-2-27 / 29
EMC Immunity	ESD (IEC 61131-2, IEC 61000-4-2) EFT (IEC 61131-2, IEC 61000-4-4) RS (IEC 61131-2, IEC 61000-4-3)
Operating Environment	Operating temperature: 0°C ~ 50°C; Storage temperature: -20°C ~ 70°C
Weight	55 g (0.12 lb)
Protection Class	IP20
Safety Certification	CE
Mounting Type	DIN-rail

Ordering Information

PC-based Motion Controller	
AX-864EP0MB1T	Standard Motion Controller (64 axes/NPN)
AX-864EP0MB1P	Standard Motion Controller (64 axes/PNP)
AX-864EP0CB1T	Advanced Motion Controller (64 axes/NPN)
AX-864EP0CB1P	Advanced Motion Controller (64 axes/PNP)
AX-832EP0MB1T	Standard Motion Controller (32 axes/NPN)
AX-832EP0MB1P	Standard Motion Controller (32 axes/PNP)
AX-832EP0CB1T	Advanced Motion Controller (32 axes/NPN)
AX-832EP0CB1P	Advanced Motion Controller (32 axes/PNP)
AX-816EP0MB1T	Standard Motion Controller (16 axes/NPN)
AX-816EP0MB1P	Standard Motion Controller (16 axes/PNP)
AX-816EP0CB1T	Advanced Motion Controller (16 axes/NPN)
AX-816EP0CB1P	Advanced Motion Controller (16 axes/PNP)

Note: Please refer to page 10 "Model Explanation" for more details.

EtherCAT Remote Modules	
R1-EC5500D0	E-Bus Remote Power Coupler
R1-EC5621D0	1-Channel Pulse Output Remote Module
R1-EC6002D0	Digital Input Remote Module (NPN / PNP); response time 100us; response time < 0.1ms
R1-EC6022D0	Input Remote Module (NPN / PNP); response time 2ms
R1-EC7062D0	Digital Output Remote Module (NPN)
R1-EC70A2D0	Digital Output Remote Module (PNP)
R1-EC70E2D0	Digital Output Remote Module (NPN)
R1-EC70F2D0	Digital Output Remote Module (PNP)
R1-EC8124D0	Digital Output Remote Module
R1-EC9144D0	Digital Output Remote Module
R1-EC5614D0	MPG Extension Module

Global Operations

ASIA (Taiwan)



Taoyuan Technology Center (Green Building)



Taoyuan Plant 1



Tainan Plant (Diamond-rated Green Building)

ASIA (China)



Wujiang Plant 3



Shanghai Office

▲ 9 Factories

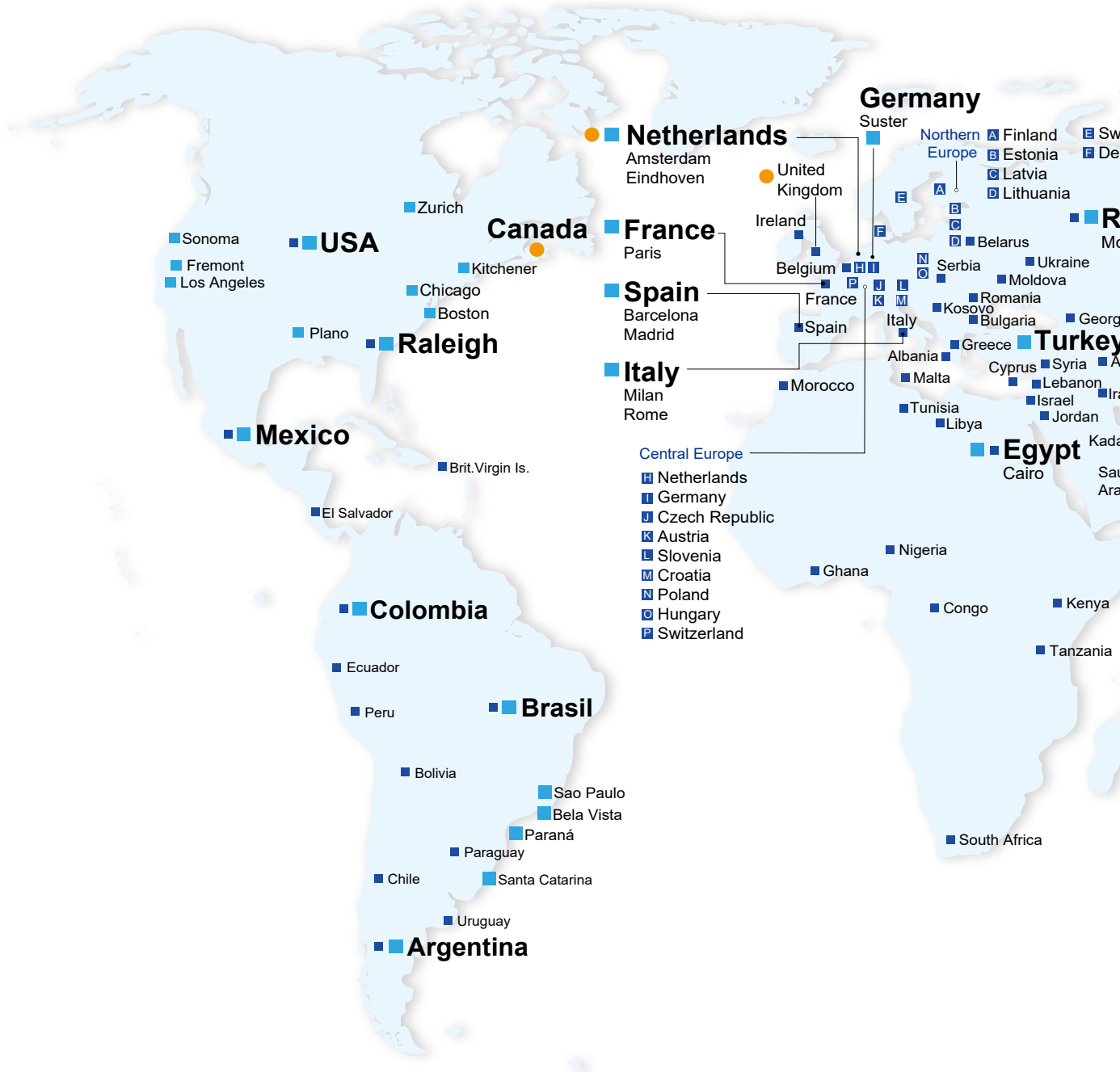

ASIA (Japan)



Tokyo Office

ASIA (India)



Rudrapur Plant (Green Building)

EUROPE



Amsterdam, the Netherlands

AMERICA



Research Triangle Park, U.S.A.

112 Branch Offices

16 R&D Centers

909 Distributors

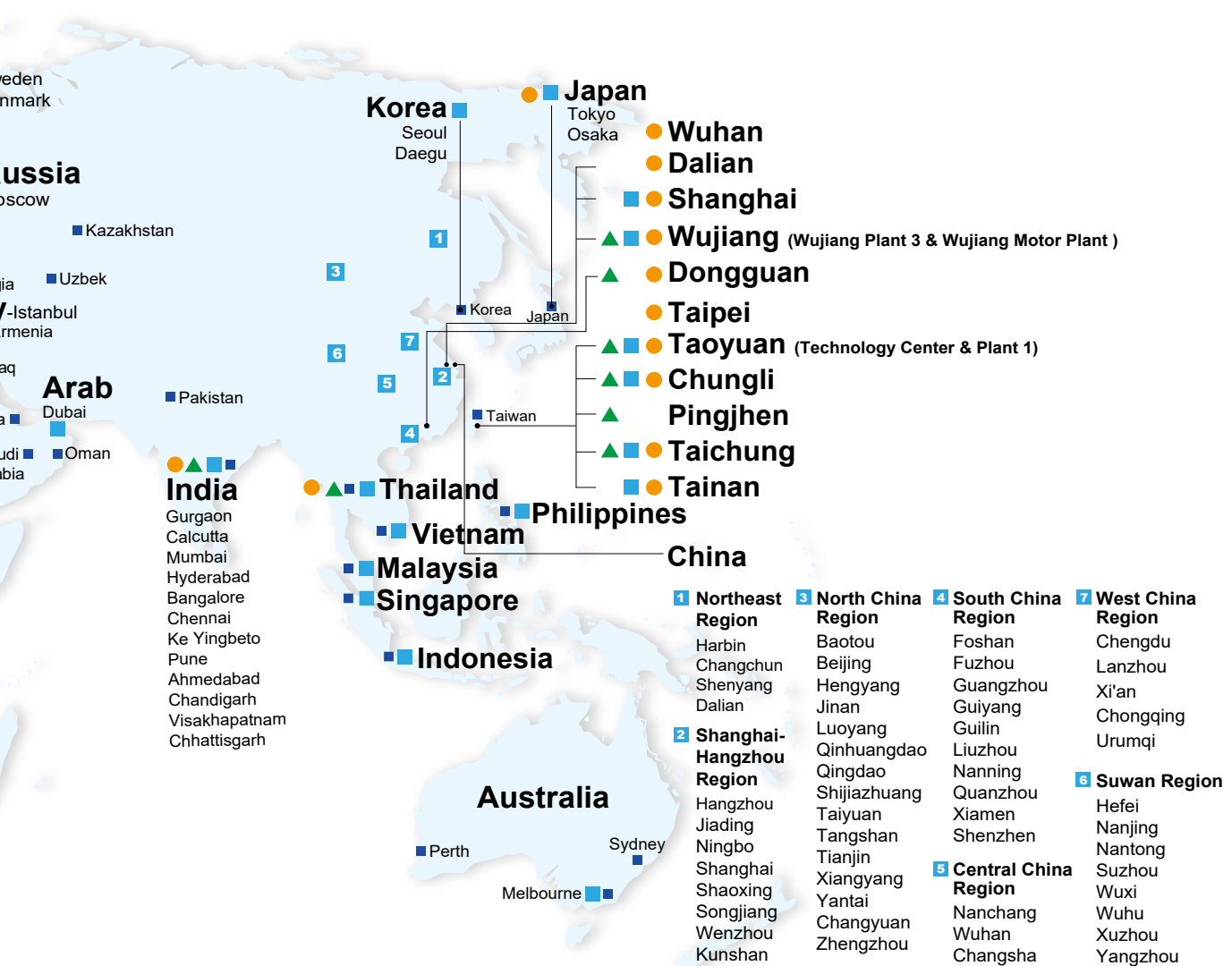



Smarter. Greener. Together.

Industrial Automation Headquarters

Taiwan: Delta Electronics, Inc.

Taoyuan Technology Center
No.18, Xinglong Rd., Taoyuan District,
Taoyuan City 33068, Taiwan
TEL: +886-3-362-6301 / FAX: +886-3-371-6301

Asia

China: Delta Electronics (Shanghai) Co., Ltd.

No.182 Minyu Rd., Pudong Shanghai, P.R.C.
Post code : 201209
TEL: +86-21-6872-3988 / FAX: +86-21-6872-3996
Customer Service: 400-820-9595

Japan: Delta Electronics (Japan), Inc.

Industrial Automation Sales Department
2-1-14 Shibadaimon, Minato-ku
Tokyo, Japan 105-0012
TEL: +81-3-5733-1155 / FAX: +81-3-5733-1255

Korea: Delta Electronics (Korea), Inc.

1511, 219, Gasan Digital 1-Ro., Geumcheon-gu,
Seoul, 08501 South Korea
TEL: +82-2-515-5305 / FAX: +82-2-515-5302

Singapore: Delta Energy Systems (Singapore) Pte Ltd.

4 Kaki Bukit Avenue 1, #05-04, Singapore 417939
TEL: +65-6747-5155 / FAX: +65-6744-9228

India: Delta Electronics (India) Pvt. Ltd.

Plot No.43, Sector 35, HSIIDC Gurgaon,
PIN 122001, Haryana, India
TEL: +91-124-4874900 / FAX: +91-124-4874945

Thailand: Delta Electronics (Thailand) PCL.

909 Soi 9, Moo 4, Bangpoo Industrial Estate (E.P.Z),
Pattana 1 Rd., T.Phraksa, A.Muang,
Samutprakarn 10280, Thailand
TEL: +66-2709-2800 / FAX: +66-2709-2827

Australia: Delta Electronics (Australia) Pty Ltd.

Unit 20-21/45 Normanby Rd., Notting Hill Vic 3168, Australia
TEL: +61-3-9543-3720

Americas

USA: Delta Electronics (Americas) Ltd.

5101 Davis Drive, Research Triangle Park, NC 27709, U.S.A.
TEL: +1-919-767-3813 / FAX: +1-919-767-3969

Brazil: Delta Electronics Brazil

Rua Itapeva, 26 - 3º, andar Edifício Itapeva,
One - Bela Vista 01332-000 - São Paulo - SP - Brazil
TEL: +55-12-3932-2300 / FAX: +55-12-3932-237

Mexico: Delta Electronics International Mexico S.A. de C.V.

Gustavo Baz No. 309 Edificio E PB 103
Colonia La Loma, CP 54060
Tlalnepantla, Estado de México
TEL: +52-55-3603-9200

EMEA

EMEA Headquarters: Delta Electronics (Netherlands) B.V.

Sales: Sales.IA.EMEA@deltaww.com
Marketing: Marketing.IA.EMEA@deltaww.com
Technical Support: iatechnicalsupport@deltaww.com
Customer Support: Customer-Support@deltaww.com
Service: Service.IA.emea@deltaww.com
TEL: +31(0)40 800 3900

BENELUX: Delta Electronics (Netherlands) B.V.

Automotive Campus 260, 5708 JZ Helmond, The Netherlands
Mail: Sales.IA.Benelux@deltaww.com
TEL: +31(0)40 800 3900

DACH: Delta Electronics (Netherlands) B.V.

Coesterweg 45, D-59494 Soest, Germany
Mail: Sales.IA.DACH@deltaww.com
TEL: +49(0)2921 987 0

France: Delta Electronics (France) S.A.

ZI du bois Challand 2, 15 rue des Pyrénées,
Lisses, 91090 Evry Cedex, France
Mail: Sales.IA.FR@deltaww.com
TEL: +33(0)1 69 77 82 60

Iberia: Delta Electronics Solutions (Spain) S.L.U

Ctra. De Villaverde a Vallecas, 265 1º Dcha Ed.
Hormigueras – P.I. de Vallecas 28031 Madrid
TEL: +34(0)91 223 74 20

Carrer Llacuna 166, 08018 Barcelona, Spain

Mail: Sales.IA.Iberia@deltaww.com

Italy: Delta Electronics (Italy) S.r.l.

Via Meda 2-22060 Novedrate(CO)
Piazza Grazioli 18 00186 Roma Italy
Mail: Sales.IA.Italy@deltaww.com
TEL: +39 039 8900365

Russia: Delta Energy System LLC

Vereyskaya Plaza II, office 112 Vereyskaya str.
17 121357 Moscow Russia
Mail: Sales.IA.RU@deltaww.com
TEL: +7 495 644 3240

Turkey: Delta Greentech Elektronik San. Ltd. Sti. (Turkey)

Şerifali Mah. Hendem Cad. Kule Sok. No:16-A
34775 Ümraniye – İstanbul
Mail: Sales.IA.Turkey@deltaww.com
TEL: + 90 216 499 9910

MEA: Eltek Dubai (Eltek MEA DMCC)

OFFICE 2504, 25th Floor, Saba Tower 1,
Jumeirah Lakes Towers, Dubai, UAE
Mail: Sales.IA.MEA@deltaww.com
TEL: +971(0)4 2690148